



**Karnail Singh**

*Founder, Harsons Associate*

## MISSION

“ Harsons is Dedicated to Innovate and excell in the industry to create a better everyday life and atmosphere to our customers, by creating an atmosphere of optimism, teamwork, creativity, resourcefulness by dealing with everyone in an transparent and ethical manner. ”

## VISION

“ To providing our customers safest and environment friendly product and become Leading manufacturer & Valued Supplier of Metal false ceiling, Adjustable Pallet Racking products in the National and International Market. ”



# about us

Harsons GREEN Ceilings are pioneers and one of the India's largest manufacturer of metal products. Its product range includes coated steel and aluminium, S.S. Suspended / Lay in ceiling system.

Harsons Aluminium, Stainless Steel and GI ceiling systems bring the modern concept of designing interior and exteriors with high aesthetic appeal and unprecedented utility values such as durability, weather resistance, corrosion resistance, fire safety and acoustic control, etc.

These ceilings are perfect symmetrical and futuristic looking and make interiors and exteriors stunningly elegant. Ideal for applications in Hospitals, Hotel, Kitchen, Corridors, Control Rooms, Showrooms, Shops, Petrol Pumps, Restaurants, Airport Lounges, Shop Floors and similar places.

Harsons GREEN Ceilings comes in a variety of designs including linear ceilings, tile and plank ceilings with a variety of fixed, suspension configurations. They are supplied both in aluminium and steel in powder coated or coil coated finishes also available in perforated designs for acoustic requirements.

Adoption of best practice in regard to Health, Safety, Welfare, Manufacturing and Environmental considerations, remain the foundation of our business. We take pride in our products, culture and ethos and we look forward to being of service to you.

## ❖ 2016

Introduced Harsons Green, Metal ceiling products which are environment friendly with new product range Baffle, Open cell ceiling system.

## ❖ 2010

Started a new production line for Architectural products (Adjustable Pallet Racking ) for European market.

## ❖ 2008

Harsons was awarded best ceiling supplier by Delhi Metro Railway Corporation.

## ❖ 1998

Harsons introduced different size of plank ceiling and supplied to Asian & International market.

## ❖ 1993

Harsons introduced Linear ceiling system for petroleum Industry.

## ❖ 1988

Started Manufacturing Ceiling Profile system .



HOSPITALITY 04



EDUCATION 03



OFFICES & WORK PLACE 05



LOUVER 08

# content



INDUSTRIAL 07

The image shows an industrial interior with a ceiling of square tiles and recessed lighting. A prominent red sign with the Reliance logo and the word 'Reliance' in white is visible. The background is slightly blurred, showing more of the industrial space.



AIRPORT 02

The image shows a modern airport terminal interior with a dark, ribbed ceiling and a large, open space. The lighting is bright and even, highlighting the architectural details of the terminal.



HEALTHCARE 01

The image shows a healthcare facility interior with a wooden slat ceiling and large windows. The space is bright and clean, with a modern design. The windows offer a view of the outdoors.



PETROL PUMPS 06

The image shows a petrol station with several fuel pumps. The pumps are white and blue, and the station has a clean, modern appearance. The sky is clear and blue.

**HARSONSGREEN**



*Customized Plank*

# healthcare

Harsons GREEN has successfully completed its projects in Healthcare industry by providing subtle and lively decor that gracefully adorns the ceilings with its extensive range of products. We aim at providing a creativity that can revive the sagging spirit and ensure to support a safe and colourful environment. AIIMS, GTB, GB PANT, and BATRA HOSPITAL are some of the hospitals that have experienced our expertise.



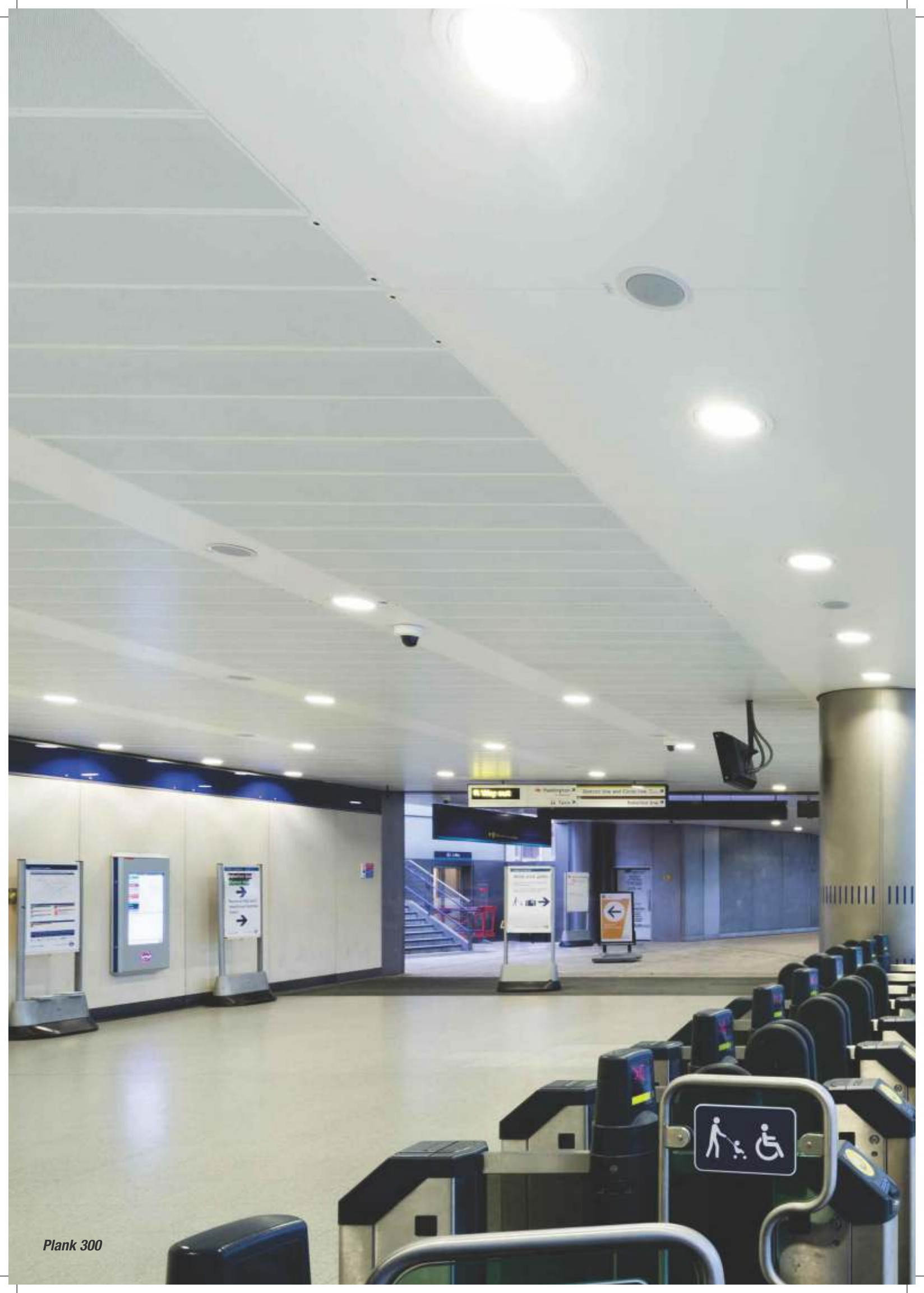



# airport

Due to their size and number of users, airports have become hugely important, representing modern, creative design and architecture. Many projects are ambitious and dictate a cutting edge innovative process and approach. Demanding designs and solutions can contribute to the huge impact that these extensive buildings can offer.

As the demand for air travel increases, airports create the first and last impression a traveller has of the country or city. In a competitive market the airport has become increasingly sophisticated, incorporating shopping malls, restaurants, hotels and entertainment facilities that contribute to revenue and provide a more attractive environment.

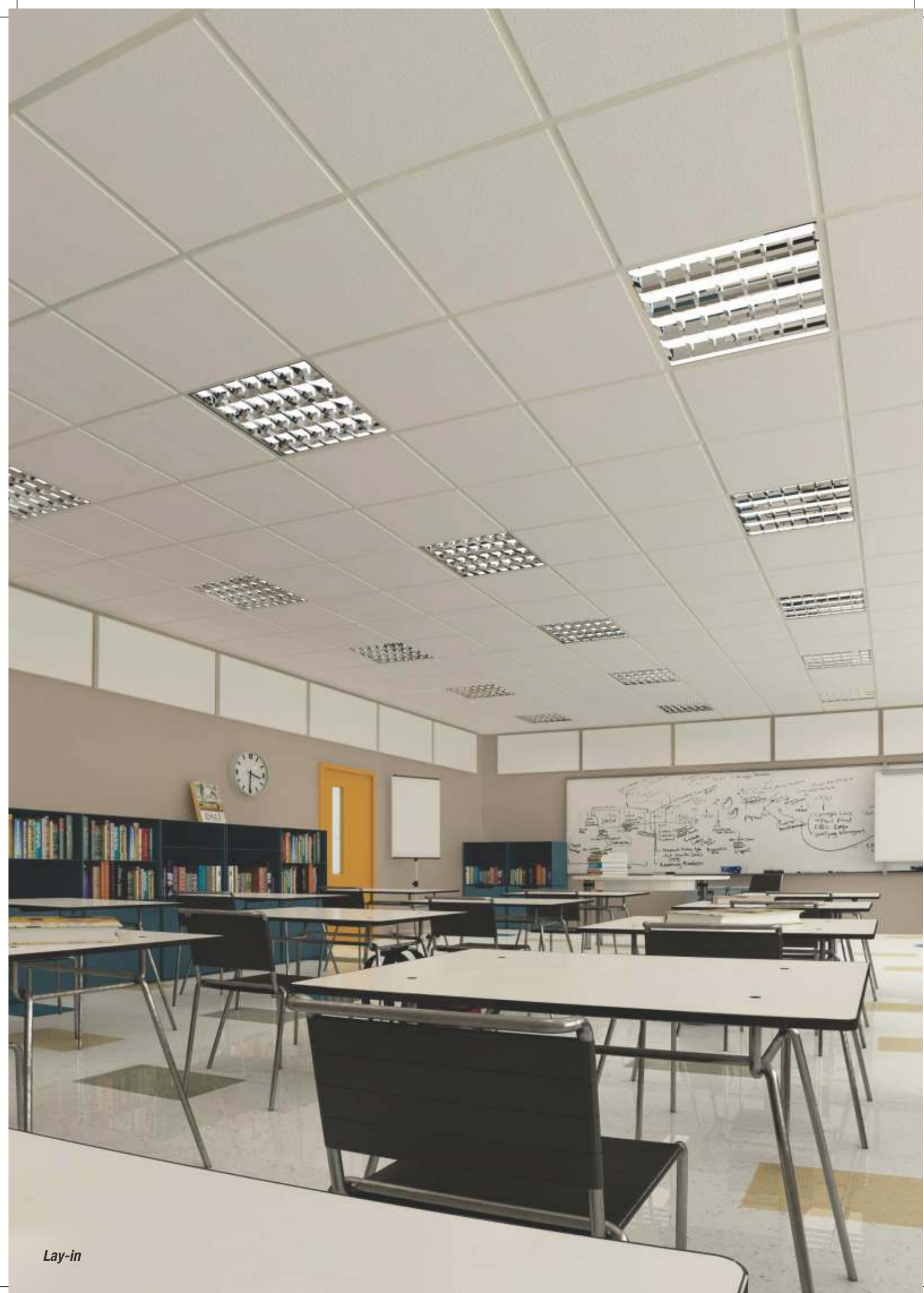

# education

The design and specification of education buildings is hugely important. The sector has various demands that ensure that the learning environment is right for children and students to be educated.

Acoustic comfort is arguably the most important requirement of an educational facility. Different areas of educational buildings will invariably have different acoustic demands: classrooms, music rooms, corridors and libraries.

It has long been recognised that the learning environment discriminates against individuals with hearing impairment and classroom design is a contributing factor. A poor acoustical environment can be as much of an architectural barrier as a set of steps are to a wheelchair user.

Durability of metal acoustic products reduces maintenance costs by being resilient to accidental and malicious damage. Cleaning is integral to the use of an educational building.

Products specified should be non-staining, easy to clean, dust free and designed for robust infrequent accessibility.

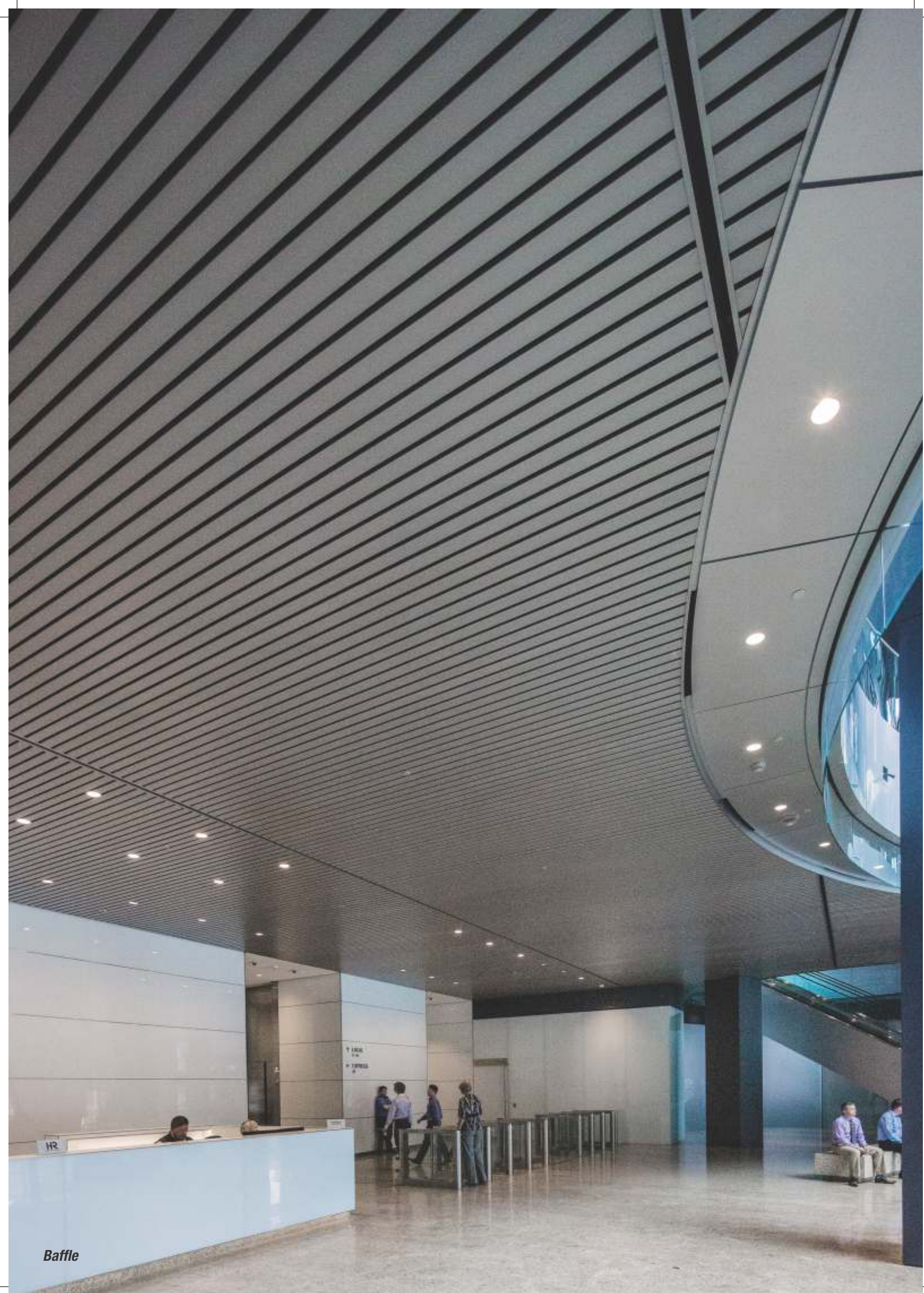

# hospitality

We have enhanced the interiors of the hotel by embellishing the ceilings with our artistic layouts. Our expertise has given a fabulous look with our wide range of products on false ceilings. The style and the decor have added additional beauty and improved its appearance by a hundredfold. Harsons GREEN proudly presents its ventures at Taj Palace, Vasant Continental, and Crown Plaza etc.





# offices & work place

The corporate world of geniuses and experts definitely need a space that is enchanting and mesmerizing to relieve them from their daily stresses. Harsons GREEN has taken every care to provide a comfy and cozy environment by adorning their ceiling with exotic and authentic decor that can rejuvenate the spirit of the workforce. We have ensured to provide the best data center solution that aims at the safety of the employees and aesthetics of the office space. We have successfully placed our lasting impressions in some of the well-known IT giants.







# petrol pumps

Panel ceilings made from aluminium/G.I. are very easy to keep clean.

These ceilings systems are suitable for Restaurants, Petrol stations, Exhibitions, Airports, and other Public environments.

They can be used both indoors and outdoors and effectively hide installations such as ventilation and cable racks.

Manufacturing of all kinds of linear strips false ceilings width 84-100-150-200-300 mm, made of .0,6-0,7 mm thickness.

Suggested and recommended for all Outside installations, External claddings, Petrol stations, CNG stations, Roofings, Car-wash, outside corridors.

All supporting systems are seismic lock, high resistance torsion and wind proof.



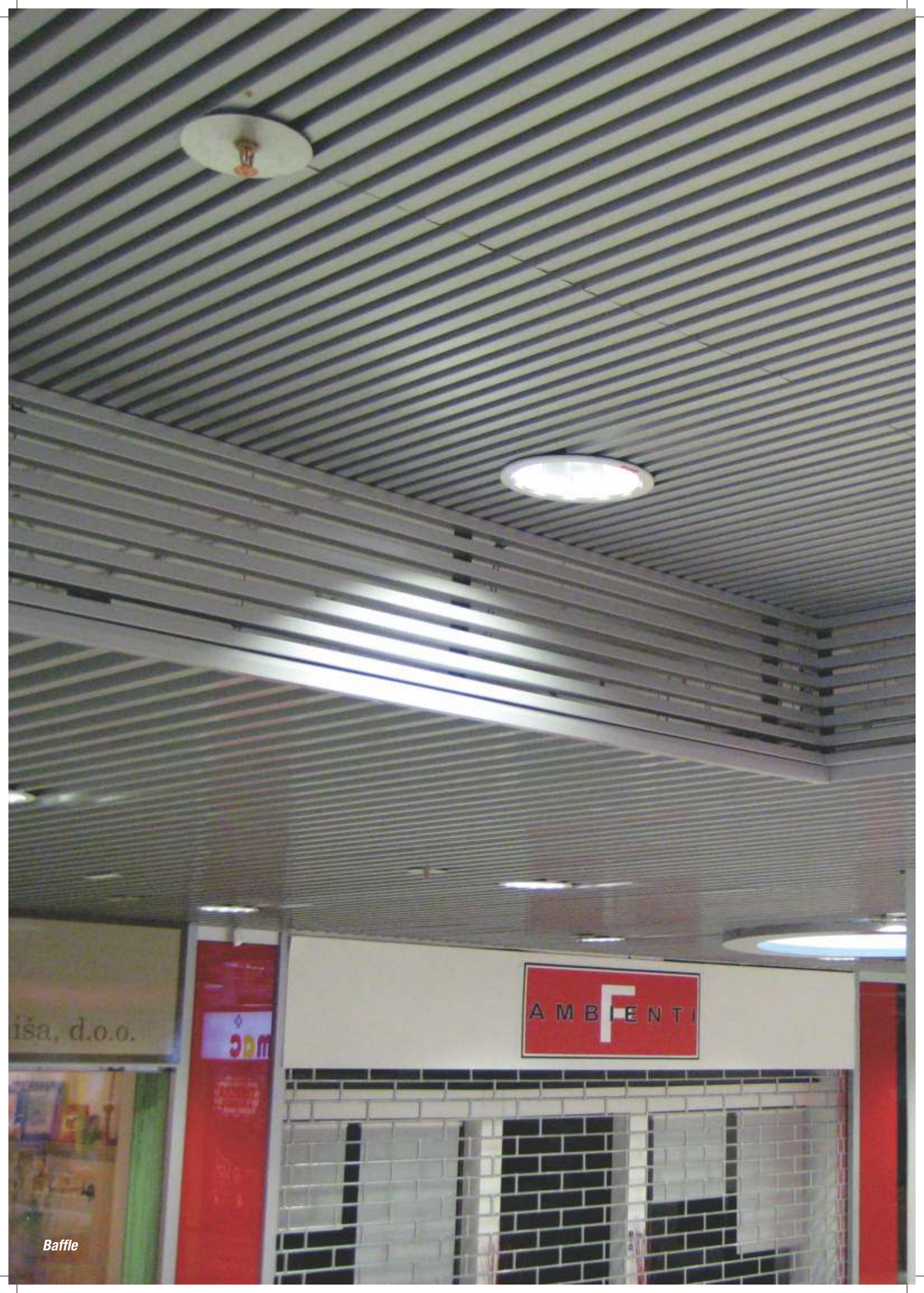

AMBIENTI  
F

iša, d.o.o.

30m

Baffle

# retail shops & malls

To allure the attention of more visitors and provide a safe and best environment, Harsons GREEN with its team of experts has designed the ceilings of Malls and Super Markets.

We have provided a layout that is customized according to the customers' requirements. We create an outlook that reflects our dedication, passion, and hard work.

Feel our presence and cherish our efforts at Mega Malls and Super stores.





*Louver*

# louvers

## Features & Benefit

- C shaped profile, roll formed louvers
- Light Weight clip in carrier system
- Durable with minimum maintenance required
- Application for both interior and external designs
- Polyester powder coating, PVDF coated, Various colors & woodgrain colors available for choice.
- 85R Louver blades can be plain or perforated for choice
- Vertical and horizontal installation are available, there are 5 different carriers for choice.



*Open Cell*

# open cell ceiling system

Open cell ceiling tiles are designed to lay-on to 15mm Tee Grid. These tiles can be used without any tee grid system also. Access is gained by simply lifting the tiles out of the grid. The new Lock-In system features open cell ceiling panels with no frame or border around them. The tiles simply connect to each other with easy lock-in system of main and cross.

When grid system is not required, the Lock-In system of Main and Cross provides architects and designers with additional flexibility, especially in customized sizes and different colors.

## **Advantages**

Easy access to lighting, ventilation systems and sprinklers strong sense of three-dimension

The product can be match with all type of light fixtures.

The product plays a prominent role in exhaust ventilation

Versatile range of patterns, configurations and colors

Available in various interior cell sizes

Eco-friendly





# baffle

Baffle Ceilings create unique room atmospheres. These open ceiling constructions impress both with outstanding acoustics and the impressive possibilities of room layout. The free space between the baffles is optimally suitable for the integration of luminaires, sprinkler, ventilation systems or similar.

No matter what your space – Bar, Office, Library, School, Lobby – sound matters. Use Harsons Green Baffles to design spaces that look great with the right kind of sound. Direct mount or hang them from the ceiling at any height to create your own distinct style.

Typically used to provide high levels of acoustic absorption in:

- Schools
- Offices
- Leisure centres
- Transport hubs, etc.

Harsons Green Baffles provide absorption across their complete surface and edge profile, delivering a high level of performance beyond that of more traditional ceiling options.

# 84R/F

## Material

**Panels:** Round edge panels, 84mm wide x 16mm deep, formed out of 0.50mm thick Aluminium alloy AA3105 / AA5050 and Glavanized sheet with powder coated finish / stove enameled coil coated on the exposed side and alkyd primer coating on the back.

**(Colour according to Harsons colour chart and availability chart)**

Panel length upto 6m

When perforated, hole diameters are 2mm at 5mm center (standard) or 1mm at 2.5mm center (micro perforated), the holes representing 15% of the perforated area.

**Panel Carriers:** 32mm wide, 39 mm deep, made out of .60mm Glavanozed steel / .95mm Aluminium made of double backed enameled black color with cutout to hold on panel in a module of 90/100mm (gap 6/16mm open). Optional gap closures with recessed or flush join profiles for 16mm gap.

**Flush join Profiles:** Made of enameled Aluminum, for 100mm module (16mm gap).

**Suspension:** By means of suspension rods and spring clips. One suspension for every 1.5 to 2 sq.m.

**Panel Span:** 1.3m max. with insulation, 1.5m max. without insulation.

Carrier Span: 1.3m max. spacing of suspension rods.

## Finish

**Coil Coated:** Panels will be finished on exposed side with 20 microns polyester coil coating over primer and on rear side with a wash coat.

**Powder Coated:** Panels will be finished on exposed side with 50 micro epoxy polyester powder paint.

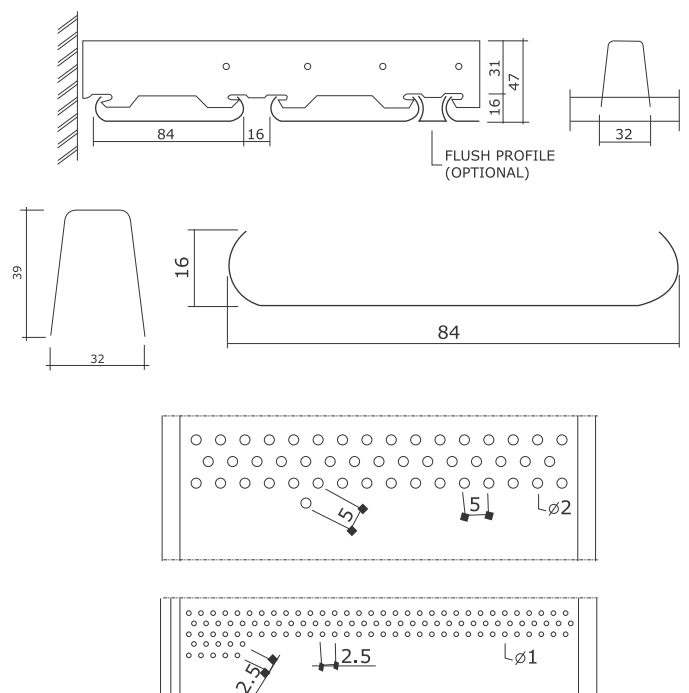

# 84C

## Material

**Panels:** Square edge panels, 84mm wide x 12.5mm deep, with a recessed flange of 23.5mm, made out of 0.50mm Aluminium alloy AA5050/AA3105 and Galvanized steel with powder coated finish / stove enameled coil coated on the exposed side and alkyd primer coating on the back.

**(Colour according to Harsons colour chart and availability chart)**

Panel lengths up to 6mtr.

**Panel carriers:** 32mm wide at the bottom, 39mm deep formed out of 0.6mm thick Galvanized steel sheet / 0.95mm Aluminum made of double backed enameled black color with protruding ears to hold panels in a module of 100 mm (84C) or closed gap 16mm

**Suspension:** By means of suspension rods and spring clips. One suspension for every 1.5 to 2 sq. m.

**Panel Span:** 1.3m max. with insulation, 1.6m max. without insulation.

**Carrier Span:** 1.2m max. spacing of suspension

## Finish

**Coil Coated:** Panels will be finished on exposed side with 20 microns polyester coil coating over primer and on the rear side with a wash coat.

**Powder Coated:** Panels will be finished on exposed side with 50 microns epoxy polyester powder paint.

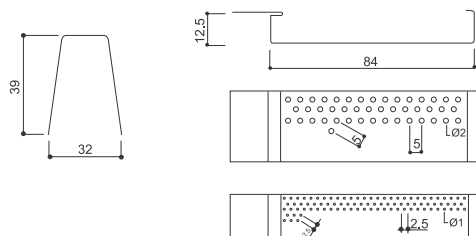
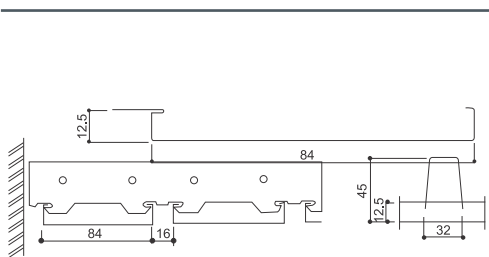
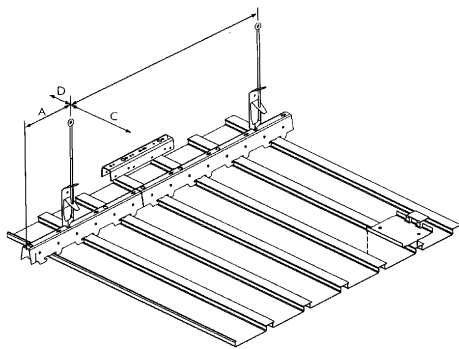

# 150F/200F

**Specifications:** 150F / 200F ceiling system comprising panel, 150mm / 200mm wide x 17mm deep roll formed out of 0.50mm thick Aluminium alloy AA 3105 / AA 5050 & Galvanized sheet with powder coated finish / stove enameled coil coated on the exposed side and alkyd primer coating on the back.

**(Colour according to Harsons colour chart and availability chart)**

Panel length upto approx 5m

**Stringers:** Roll-formed carrier 34.5mm wide x 48mm deep out of 0.6mm thick steel / 0.95mm Aluminum made of double backed enameled black color, cuts to holed panels in a module of 150mm / 200mm

**Suspension:** By means of suspension angle.

**Panel Span:** 1.5m max. with insulation, 1.8m max. without insulation.

**Stringer Span:** 1mtr.-1.2mtr. max. spacing of suspension rods.

## Finish

**Coil Coated:** Panels will be finished on exposed side with 20 microns polyester coil coating over primer and on the rear side with a wash coat.

**Powder Coated:** Panels will be finished on the exposed side with 50 microns polyester powder paint.

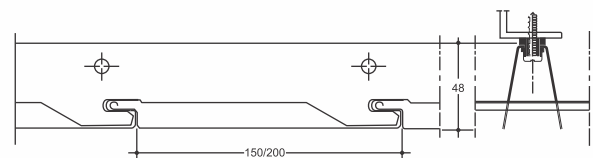

# 75C/150C/225C



Harsons Ceiling type 75C/150C/225C distinguishes itself from the other types because of its smooth, closed appearance. The panels about each other with a narrow A-groove. They are installed to carrier profiles and can be simply demounted individually, by inserting a plain strip between the panels.

As with all Harsons Ceilings, the 75C/150C/225C can be applied in all types of buildings and because of their closed appearance they are particularly suitable for domestic applications: corridors, offices etc.

**Panels:** 75/150/225 mm wide x 15 mm deep bevel edge, roll formed out of 0.50 mm thick Aluminium alloy AA 3105/AA5050 & Galvanized Steel sheet with powder coated finish / stove enameled coil coated on the exposed side and alkyd primer coating on the back.

**(Color according to Harsons color chart and availability)**

**Panel Carrier:** 32mm wide, 39mm deep made out of 0.6mm Galvanized steel out of .6mm thick steel / 0.95mm Aluminium made of double backed enameled black color, cuts to hold panel in a module of 75 mm/150mm/225 mm.

**Suspension:** By means of G.I. rod hangers and suspension clips.

**Panel Span:** 1.3m max. with insulation, 1.5m max. without insulation.

**Carrier Span:** 1.3m max. spacing of suspension rods.

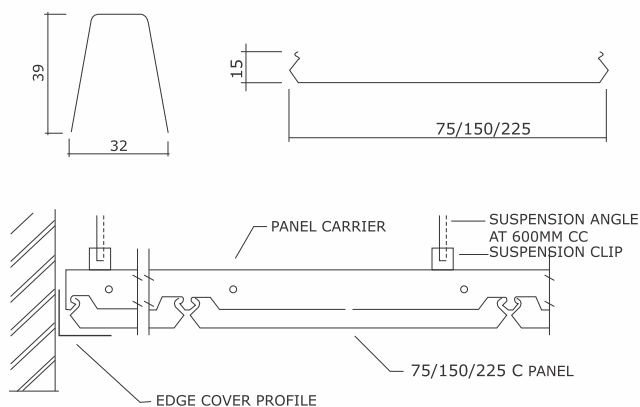

## Finish

**Coil Coated:** Panels will be finish~on 'exposed side with 20 microns polyester coil coating primer and on the rear with a wash coat.

**Powder Coated:** Panels will be finished on the exposed side with 50 microns epoxy polyester powder paint.

# Lay-in System

## System Features

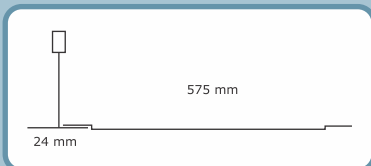
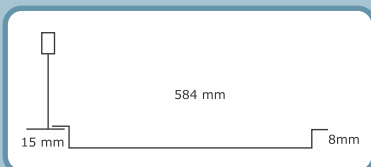

## Lay-in-System

Suspension system is standard 15/24 mm table exposed metal grid. Grid features 38mm high main runners and cross tees, roll formed from galvanised steel to BS 2989 Z-18 zinc coating. The main runners feature bayonet ends and the cross tees stab ends for quick and simple coupling. The runners are pre-slotted to construct a variety of layouts. The main and cross runners are provided with a coil coated steel capping on the exposed table in off-white colour. The grid is suspended from the roof with GI wire rod and quick adjustment suspension hangers along the runners. The grid system is designed to satisfy ASTM C635 intermediate duty loading and deflection criteria. This system is only suitable for interior use.

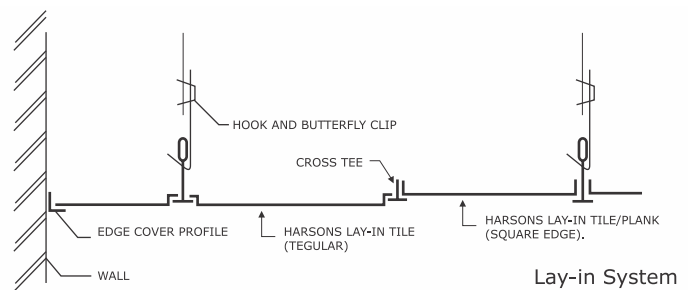

## Edge Cover Profile

Tiles/Planks are trimmed along the wall perimeter by means 23X23mm roll formed steel or aluminium edge cover profile.

## Paint Finish

Steel tiles/planks are finished on exposed side with backing coat on rear surface (nominal 5 microns), or with a 50 micron epoxy polyester powder coating on exposed surface.

Aluminium tiles/planks are finished on exposed side with 20 micron polyester coil coating over primer in approve and backing coat on rear surface (nominal 5 microns), or with a 50 micron epoxy polyester powder coating on exposed surface. Wall angles are finished with 50 micron epoxy polyester powder coating paint.

# Clip-in System

## Clip-in System

Tiles/planks are suspended by means of a suspension system comprising 0.5mm galvanized steel clip-in profiles are suspended from roof structure by GI ceiling brackets. GI suspension angles and hold-on clamps at max. 1200mm center to center along the clip in profile. This rigid suspension is also suitable for exterior use.

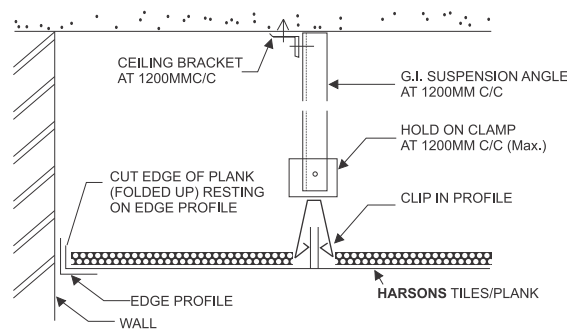

## Paint Finish

Steel tiles/planks are finished on exposed side with backing coat on rear surface (nominal 5 microns), or with a 50 micron epoxy polyester powder coating on exposed surface.

Aluminium tiles/planks are finished on exposed side with 20 micron polyester coil coating over primer in approve a shade and backing coat on rear surface (nominal 5 microns) with a 50 micron epoxy polyester powder coating on exposed surface. Wall angles are finished with 50 micron epoxy polyester powder coating.

## Perforations / Acoustic

Harsons tiles and planks are also available with perforations for providing acoustic performance characteristics. Tiles and planks are perforated as a standard with 2.5mm dia. holes at 5.5mm centre to centre glasswore mineral wool (48 kgm<sup>2</sup>) provide good sound absorption. Tiles and planks are also available with a factory applied acoustic tissue to the back side which provides good sound absorption.



The diagram shows two views of a clip-in profile: a perspective view and a top-down view. To the right, under the heading "Possible Layouts", are three grid diagrams: "Straight Joints" (a simple grid), "Staggered Joints" (a grid with staggered joints), and "Combined Tile Sizes" (a grid with varying tile sizes).

# Tile/Plank Design Ceiling

Harsons tile and plank design ceiling system has been developed to meet both practical and aesthetical requirements of modern ceilings. The major advantages of the Harsons tile/plank system are innovative suspension systems, optional rigid grid system for suspension of exterior ceilings, choice of tile material, extensive range of colours and finishes and a choice system.

The tile/plank ceiling systems are offered in polish coil coated steel and aluminum and powder coated steel and aluminium finishes and offer the advantage of easy cleaning, non-static properties and inert material. Incandescent and halogen type spot lights can be easily incorporated in the tile ceilings and fluorescent fittings within the plank ceilings.



## Tiles

Tiles are manufactured out of steel / aluminium / stainless steel on advanced equipment, which includes several levelling stages in the manufacturing process.

For the clip-in tile, two sides of each tile are raised and pipped and stopped to ensure positive engagement into the spring tee, yet allow demounting of individual tiles.

All tiles have square/bevelled edges.

## Planks

Planks are manufactured out of aluminium / steel / stainless steel produced on advanced equipment which includes several levelling stages.

Clip-in plank: The short sides of each plank are raised and pipped and stopped to ensure positive engagement into the spring tee, yet allow demounting of the individual plank.

## Installation of Tiles

Parameter tiles are installed first by engaging the cut edge into the edged trim and then securing the profiled edge into the runner. The tiles are secure to the runners by applying an upward pressure using the palm of the hand at the corner. Corner tiles must be installed before adjacent perimeter tiles.



## Dismantling

It is possible to remove individual tiles anywhere in the ceiling. To remove, insert the Dismantling Tool close to the corner in the joint line at right angles to the clip in Runner direction. Each corner is disengaged by pulling down the dismantling tool.





# 300 C Metal Ceiling Panels



300C metal ceiling panels offer a subtle, long span design for interior ceilings. This panel features a butt-joint, “bevel edge” that moderates panel-to-panel connections for an orderly, finished design.

## KEY FEATURES

- Panel width: 300 mm
- Panel length: 600mm to 6000mm
- Panel Design: Bevel-edge
- Waste reduction with factory fabricated dimensional material
- Down weight: reduce dead load with light weight Aluminium
- Easy plenum access
- Interior and exterior applications
- Compatible with industry standard
- Lighting, HVAC, speaker, fire safety, and security services



## COLORS & FINISHES

Standard colours Natural and Cotton White shown. Client-specific colours available. Minimum quantities may apply.

## TYPICAL ISOMETRICS

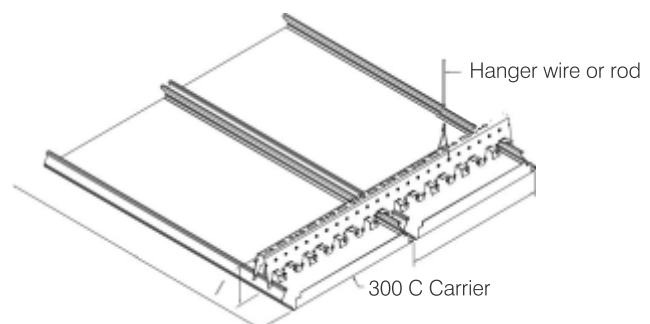

## Available Patterns



Non-perforated



Perforated



# Sun Control System

## 84R - Sun Louvre

The Harsons Green 84R Sun Louvre system is a real classic, used for applications on straight, curved or angled façades. The product has an elegant and light appearance with nicely rounded edges.

- Roll formed aluminum panels of 84 mm wide
- Panels in fixed position on a variety of stringers with different louvre inclination, which determine the amount of outward and inward vision
- A variety of carrier systems with fixed or variable modules are available allowing the optimal shading solution for its application
- The Harsons Green 84R Sun Louvre system can be installed in four ways:
  - Projected horizontally at the top of the glazed area or roof edges
  - Angled projection to give even greater shading
  - Positioned vertically
  - Combination of horizontal and vertical
- Panels can be connected to achieve visually continuous lines
- Corner solutions are available
- The system can also be used as a ventilated façade system covering for example installations on rooftops or staircases

### Practical Applications

#### *- Horizontal projected 84R Sun Louvre system*

For high sun angles the horizontal application assures a constant and reliable sun control system during sunny periods.

#### *- Angled projection 84R Sun Louvre system*

For high and medium sun angles, sloped applications give even more shade.

#### *- Vertical 84R Sun Louvre system*

For lower sun angles, the vertical application allows a reliable sun control system with good visibility to the outside.

#### *- Combined 84R Sun Louvre system*

The best sun protection can be obtained using a horizontal or angled louvre in combination with a vertical 84R Sun Louvre. Maximum inside and outside visibility can be obtained using this solution.



Horizontal



Angled



Vertical



Combination



## Material Specifications

### - Base Material

- Harsons Green 84R Sun Louvre panels are roll formed from 0.6 mm thick pre-painted stove enamelled aluminium strip of a corrosion resistant alloy AA-3015 or 5050. All aluminium products can be recycled for the full 100% requiring very little energy.

### - Finishes

- Harsons Green has developed special products for the exterior environment which have properties capable of meeting the severe requirements of external use. The products come with a special high quality surface treatment: The panels get a unique finishing touch with industrial coil coating processes.
- Abrasion resistance. The topcoat also offers excellent resistance against scratches and the fine structure hides minor damage incurred during installation
- Corrosion resistance. The alloy and pre-treatment ensure optimal corrosion resistance. Harsons Green products have been subjected to real-life test as well as laboratory corrosion and UV tests.

### - Harsons Green Colour Range

There is a wide standard colour range for Harsons Green 84R Sun Louvres. See the Harsons Green Exterior colour program. Other (RAL or NCS) colours available on request.

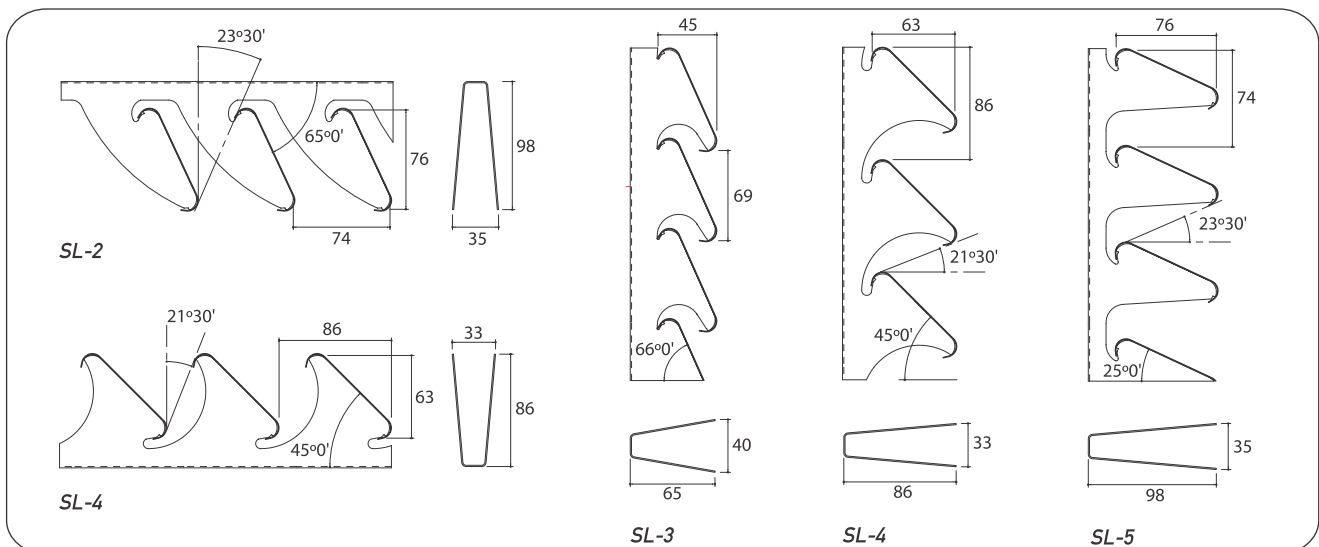
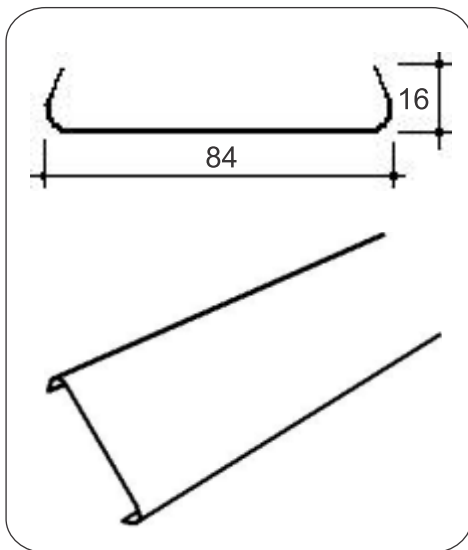

# Hi Rib roofing and Clip on roofing

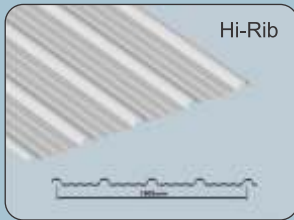

A pierced fixed roof and wall covering system, consists of structurally-engineered profiled panels that are available in single length (up to 12 metres) and are fixed by means of self-drilling fasteners. All the ribs are clipped on and are interlocked. No penetration is done for its fixation to the roof or wall framing.

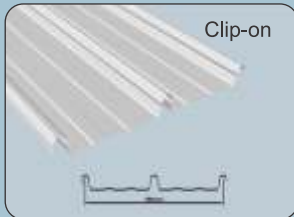

A concealed fixed snap-on seam roof/wall covering system that consists of structurally strong high-ribbed panels with wide-fluted pans for efficient water shedding and are fixed by means of concealed clips. All the ribs are clipped on and are interlocked. profile completely water-tight. The side lap is totally weatherproof. Any moisture drawn in by capillary action is trapped and dispersed by normal run-off.

Harsons Green concealed fix roofing profiles are developed to suit a variety of structural applications and to withstand harsh environmental conditions. Revolutionary heavy duty clips have replaced conventional screws in both the Hi rib and Clip on products, ensuring a promise of no leakage. Thanks to such innovative design, Harsons Green roofing profiles are able to accommodate thermal movements and expansion and eliminate sources of possible corrosion.

When considering the long term benefits of Harsons Green concealed fix roofing profiles, our customers are promised a smarter alternative to conventional and out-dated profiles.

All the roof and wall coverings are supplied with custom accessories such as flashing, cappings, futters, trims, fasteners, etc. which are formed out of the same substrates and coatings as the roof and wall covering panels.

Harsons Green profiles are available in both ribbed and flat panels to give a variety of finishes for attractive roofing and cladding of domestic, commercial and industrial applications. The profiles are available in the following standard finishes:

- Bare Gavalume steel
- Gavalume steel colour coated
- Steel colour coated



# Perforation Patterns

Perforation patterns are increasingly used as active design elements in the ceiling surface. The shape of the holes, the patterns, and the colour options of the acoustic felt provide unique design combinations.

HARSONS offer a range of standard perforation pattern as detailed below. These patterns can be supplied with plain borders and as blocks of perforations within a tile. Further perforation patterns can be made available upon request.

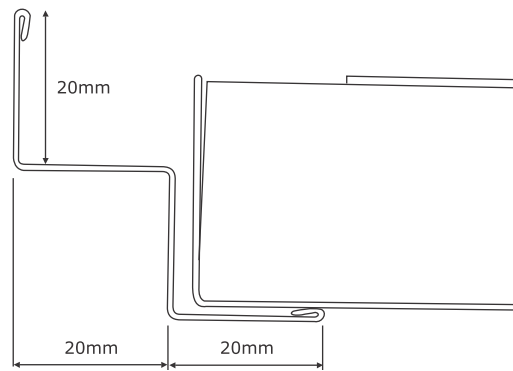
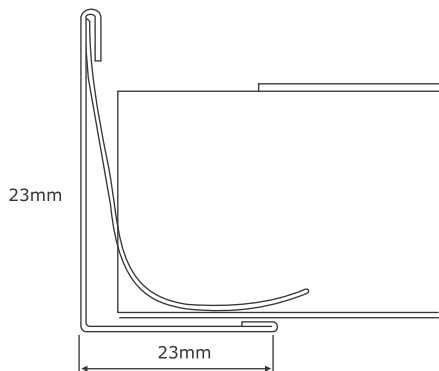

Perimeter Details



**HARSONS &  
ASSOCIATES**



# Adjustable Pallet Racking

APR (Adjustable Pallet Racking ) is the first choice for the safe and efficient storage of Palletised goods, It is widely specified in virtually every industry, as It is highly adjustable it can easily adapt to the vast range of products to be stored, which can include the safe storage of non-palletised loads. The adjustable racking can be tailor- made to meet your precise requirements, as all beams are height adjustable the racking can easily be adapted to cater for any change in the type or size of goods stored.

Our comprehensive range, complimented by an extensive array of accessories offers one the most varied pallet racking solutions available, the addition of simple accessories enables you to store the more unusual items such as coils , drums , steel cage pallets and many other items.

Designed for strength, durability, ease of assembly and operational reliability , the Alser system comprises a comprehensive choice of frames and beams which can be precisely selected and combined to meet the requirements of any storage application.

Alder UK Ltd are able to design pallet racking around the customer's needs, optimizing space and efficiency giving real long term value for money. Our dedicated team of specialists will work with you through all the stages of the project, providing detailed design, construction, supply, installation and commissioning to meet your exact requirements. Our designs meet and exceed all current European and SEMA Design Specifications and is in compliance with Bs5950 and IS800/801.

## Technical Specifications for our Adjustable Pallet Racking

- Frame Heights: 2.0m to 8m (Higher sizes also available )
- Frame Depths: 600mm to 1200mm
- Beam Widths: 1m to 4m
- Loading Capacity: 1ton to 25ton per Bay
- Finish's Available: Powder Coated
- Pre- Galvanized & Hot Dipped Galvanized

## Our Adjustable Pallet Racking can be used to store a wide variety of products which include

- Heavy Duty Pallets
- Metal Sheets
- Metal Coils and Metal Castings
- Metal Extrusion & Tubes
- Pipes
- Furniture
- Cables and metal Sections
- Dies & Tools

## Configurations for Adjustable Pallet Racking include

- Flow Rack
- Pushback Rack
- Double Depth Rack
- Dynamic Rack
- Drive-in Rack and Drive-thru Rack
- Mobile Rack
- Rack Supported Mezzanine
- Rack Supported Buildings
- Custom Configurations

## Optional Accessories for Adjustable Pallet Racking include

- Frame Protector
- Pallet Supports
- Decking Supports
- Rack Stabilizer
- Run Spacer
- Sprinkler Supports
- Pallet SAFETY Bar with Saddle Bracket
- Drop over Panel
- Barrel Chock
- Fork Clearance Bars
- Decking-Timber & Hardboard
- Drum Cradle
- Post Pallet Channel
- Rack End Barrier-Square & Round
- Stock D Dividers

# Our Esteemed Clients



Thank you for your valued business



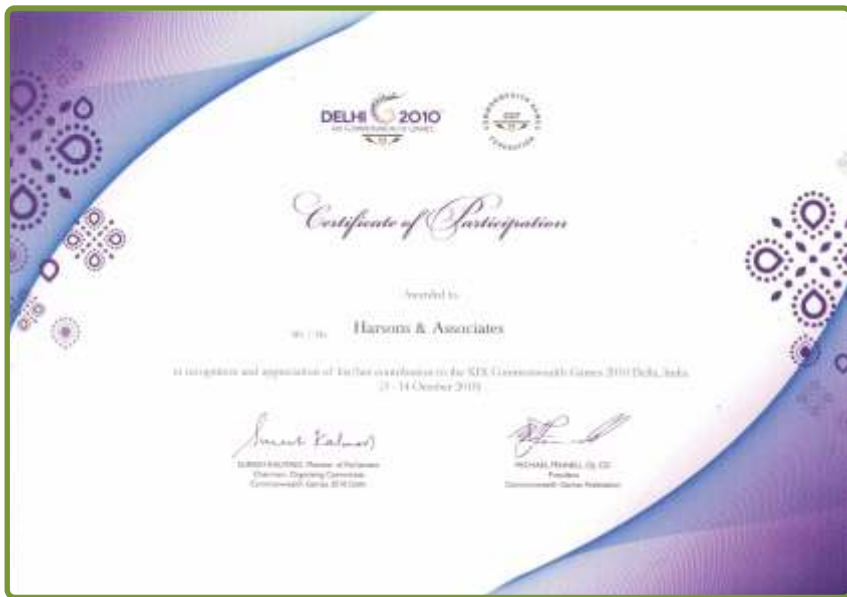





[www.harsonsgreen.com](http://www.harsonsgreen.com)



## **HARSONS & ASSOCIATES**

### **UNIT- I**

F-653, Sanjay Gandhi Memorial Nagar  
K.C. Badkhal Road, N.I.T. Faridabad 121001(Haryana) INDIA

### **UNIT- II**

PLOT NO D-6 & D-7F.I.T SECTOR - 57,  
BALLABHGARH ( HARYANA)

Tel.: +91-129-4038502/03/04, 4051506/07/08

Email: [harsonsceiling@gmail.com](mailto:harsonsceiling@gmail.com), [info@harsonsassociates.com](mailto:info@harsonsassociates.com)

[www.harsonsgreen.com](http://www.harsonsgreen.com)



## **HARSONS & ASSOCIATES**

### **UNIT- I**

F-653, Sanjay Gandhi Memorial Nagar  
K.C. Badkhal Road, N.I.T. Faridabad 121001(Haryana) INDIA

### **UNIT- II**

PLOT NO D-6 & D-7F.I.T SECTOR - 57,  
BALLABHGARH ( HARYANA)  
Tel.: +91-129-4038502/03/04, 4051506/07/08

Email: [harsonsceiling@gmail.com](mailto:harsonsceiling@gmail.com), [info@harsonsassociates.com](mailto:info@harsonsassociates.com)

Marketing Partner:



### **GORAYA BUILDTECH**

Unit No. 5 ( GF ), Building No. B-18  
B-1, Community Center, Janakpuri  
New Delhi-110058,  
Phone: 011-49054576,  
Email- [info@gorayabuildtech.com](mailto:info@gorayabuildtech.com)